

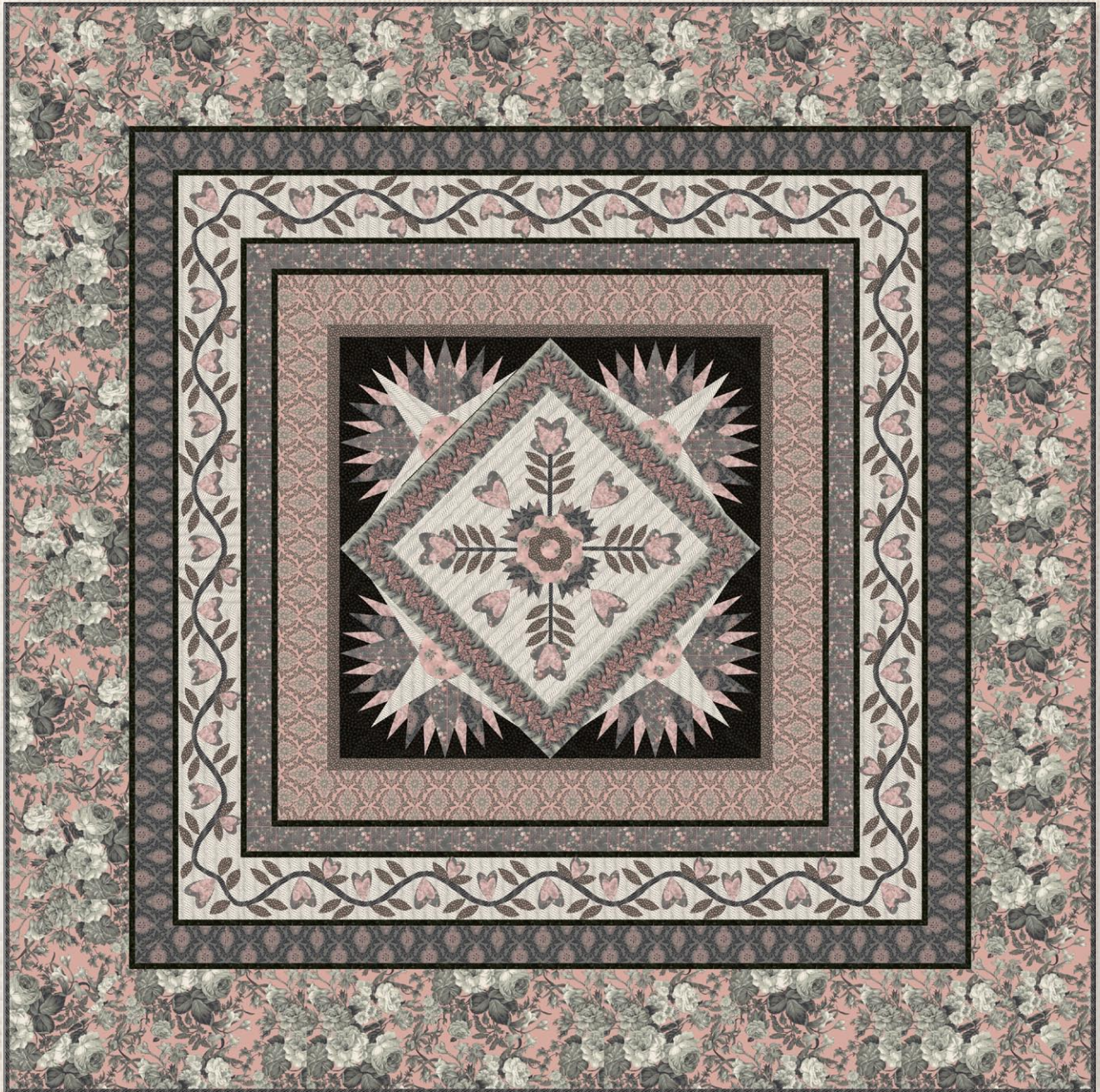

**NORTHCOTT**  
*Cottons that feel like silk*

*Sophisticate*

Northcott Free Pattern



**"Sophisticated Medallion"** by Patti Carey  
88" square, advanced skill level

**Northcott USA**  
1099 Wall St. West, Suite 135  
Lyndhurst, NJ 07071  
201.672.9600

[WWW.NORTHCOTT.COM](http://WWW.NORTHCOTT.COM)

**Northcott Canada**  
640 Rowntree Dairy Road  
Woodbridge, ON Canada L4L 5T8  
905.850.6675



# Sophisticated Medallion

This stunning queen-size quilt showcases Sophisticate, a Quest for a Cure collection by Northcott. Make it in the elegant Vintage Rose as shown, or the Classic Taupe/Black. Use your favorite method for the appliqués (quick-fused, freezer paper, needle-turn). For complete paper-piecing instructions, please refer to one of the many excellent paper-piecing books available in your quilt shop.

**Finished Quilt Size:** 88" square

**Skill level:** Advanced

Fabric Requirements	SKU	Yards	Cutting Instructions
<b>Fabric A</b> light helix	2471-90	1 $\frac{7}{8}$ yds	Cut 7 strips 5 $\frac{1}{2}$ " x width of fabric (wof); join in 3's and cut (2) 60 $\frac{1}{2}$ " pieces & (2) 50 $\frac{1}{2}$ " pieces (6 <sup>th</sup> border). Cut (1) 18 $\frac{1}{2}$ " square (center block). Reserve scraps for paper-pieced blocks.
<b>Fabric B</b> feather stripe	2465-91	$\frac{7}{8}$ yd	On lengthwise grain, cut 4 strips 3 $\frac{1}{2}$ " centering the feather part in the strip (center block frame).
<b>Fabric C</b> rose spaced floral	2468-22	fat $\frac{1}{8}$	Cut out one piece of Applique template #1 & #3, and 4 pieces of Block template #14, adding seam allowances as necessary.
<b>Fabric D</b> dot	2472-92	$\frac{3}{4}$ yd	Cut 4 strips 1 $\frac{1}{2}$ " x wof (1 <sup>st</sup> border). Cut 40 pieces of Leaf #9 & 160 pieces of Leaf #8, adding seam allowances as necessary. Cut 1 piece of Applique #2.
<b>Fabric E</b> dark damask	2469-92	1 $\frac{1}{8}$ yds	Cut 6 identical strips approximately 4 – 4 $\frac{1}{2}$ " high x wof; trim strips to 3 $\frac{1}{2}$ " by trimming off top edge of each strip. Join end-to-end and cut into 4 equal pieces (8 <sup>th</sup> border). Cut 4 pieces of Applique #4 and reserve balance for paper-pieced blocks.
<b>Fabric F</b> rose calico	2470-22	$\frac{1}{2}$ yd	Cut 8 pieces of Applique #5, 40 pieces of Applique #12 & 20 pieces of Applique #10, adding seam allowances as necessary. Reserve balance for paper-pieced blocks.
<b>Fabric G</b> calico stripe	2467-92	1 $\frac{1}{4}$ yds	Cut 6 strips 2 $\frac{1}{2}$ " x wof; join end-to-end and cut into (4) 52" pieces (4 <sup>th</sup> border). Cut 8 pieces of Applique #6, 4 pieces each of Applique #7 & 7Reverse, 40 pieces of Applique #13 & 20 pieces of Applique #11, adding seam allowances as necessary. Reserve balance for paper-pieced blocks.
<b>Fabric H</b> dark helix	2471-94	1 $\frac{1}{4}$ yds	Cut 10 strips 2 $\frac{1}{2}$ " x wof; join end-to-end, press in half and reserve for binding. Cut balance into bias strips as follows: 24" of 1" strips (for center block), and 350" of 1 $\frac{1}{2}$ " strips (for 6 <sup>th</sup> border).
<b>Fabric I</b> black texture	2130-99	1 $\frac{1}{2}$ yds	Cut 25 strips 1" x wof; join end-to-end as required and cut (4) 48" pieces (3 <sup>rd</sup> border), (4) 53" pieces (5 <sup>th</sup> border), (4) 64" pieces (7 <sup>th</sup> border) & (4) 71" pieces (9 <sup>th</sup> border). Cut 4 pieces each of Block template #15, 15Reverse & 16 (tape the 2 template pieces together). Reserve balance for paper-pieced blocks.
<b>Fabric J</b> rose damask	2469-22	1 $\frac{1}{8}$ yds	Cut 5 identical strips at least 4 $\frac{1}{2}$ " x wof; trim strips to 4 $\frac{1}{2}$ " by trimming off top edge of each strip. Join end-to-end and cut into 4 equal pieces (2 <sup>nd</sup> border).
<b>Fabric K</b> large floral	2464-91	2 $\frac{3}{4}$ yds	Cut 4 lengthwise strips 10 $\frac{1}{4}$ " wide.
Backing	(2466-22)	7 $\frac{1}{4}$ yds	Cut (2) 96" pieces. Cut balance in half lengthwise, join end-to-end and center between 96" pieces.
Batting			A piece 94" x 94"
Freezer paper or Wonder-Under for appliques			

### **Paper-pieced Blocks (four 17" half-blocks):**

1. Make 4 copies of the paper-piecing units A, B, C, D, E, F, G & H.
2. Fill the #1 sections with Fabric F rose calico. Fill the #2 & #3 sections with Fabric I black texture. Fill the #4 sections with Fabric E dark damask. Fill the #5 sections with Fabric G calico stripe. (Hint: I pre-cut my pieces of each fabric, adding  $\frac{3}{8}$ " seam allowance to the finished size of each section. This saved a lot of ripping out.) Trim each unit along the outer dotted lines.
3. Sew units G, C, A & E together. Sew units H, B, D & F together. Gently remove the paper in the seam allowances between units.
4. Using templates I1, J1 & K1, cut out 4 pieces of each, laying the pieces on the lengthwise grain to showcase the motif on the fabric.
5. Sew a G-C-A-E unit to left side of each I1 piece, then add an H-D-B-F unit to right side, pressing seams toward I1.
6. Add a J1 piece to the G edge of the block, and a K1 piece to the F edge of the block, pressing seams toward J & K. Insert a Fabric C #14 piece in center, matching centers, with Fabric C piece on the bottom and the paper-pieced unit on the top. Press seam toward Fabric C.
7. Sew a Fabric I #15 & #15 Reverse piece onto each end of a #16 piece; press seams open. Lay this unit on top of the paper-pieced unit, matching seams and centers at points and having edges aligned; sew. Press seam toward #15/16. Make a total of 4 of these blocks. Give yourself a pat on the back!

### **Center Appliqued Block:**

1. Fold the 18 $\frac{1}{2}$ " Fabric A square in quarters and press gently to mark center and mid-point on each side. Tape the 2 Block layout pages together, matching dotted lines. This will give you a layout for  $\frac{1}{4}$  of the block. Note that the vertical and horizontal lines are a reference for the center and mid-points.
2. Using the Block layout pages as a guide, arrange the Applique pieces #1, 2, 3 & 4 in the center of the Fabric A square. Cut the 1" Fabric H bias into 6" lengths and add to block, tucking inner edge under center appliqué. Add the #8 leaves, the #7 pieces, and the #6 & #5 hearts, positioning the hearts on top of the stems.
3. Hand- or machine-stitch or fuse in place using your favorite method of appliqué. If fusing, finish the edges using a satin- or blanket-stitch and matching thread, inserting a piece of Pellon Stitch-n-Tear under the block to prevent stretching. Remove as much of the Stitch-n-Tear as you can after stitching.

### **Building the Quilt:**

1. Center and sew a Fabric B strip onto each edge of the center appliqué block, sewing from seam line to seam line, and backstitching at each end. Miter corners using your favorite method.
2. Center and sew a paper-pieced block onto each edge of the quilt, pressing seam toward Fabric B.
3. 1<sup>st</sup>, 2<sup>nd</sup>, 3<sup>rd</sup>, 4<sup>th</sup> & 5<sup>th</sup> borders: Center and sew a Fabric D strip onto each Fabric J strip, pressing seams toward D. Center and sew this to each 48" Fabric I strip, pressing seam toward I. In the same way, add a Fabric G strip and a 53" Fabric I strip, pressing seams toward I. Center and sew these units to the quilt, sewing from seam line to seam line and backstitching at each end. Miter corners.
4. 6<sup>th</sup> border: Add a 50 $\frac{1}{2}$ " Fabric A strip to each side, and a 60 $\frac{1}{2}$ " Fabric A strip to top & bottom edges, pressing seam toward 5<sup>th</sup> border. Using the photo and border layout page as a guide, arrange the 1 $\frac{1}{2}$ " Fabric H bias, the remaining #8 leaves, the #9 leaves, and the #10, 11, 12 & 13 hearts in the border. Note that the #9 leaves pair with the #10/11 hearts. Stitch or fuse to border, using Stitch-n-Tear if necessary.
5. 7<sup>th</sup>, 8<sup>th</sup>, 9<sup>th</sup> & 10<sup>th</sup> border: Center and sew a Fabric E strip onto each 64" Fabric I strip, pressing seam toward I. Center & sew this to each 71" Fabric I strip, pressing seam toward I. Center and sew this unit to each Fabric K strip, pressing seam toward I. Center and sew these units to the quilt, sewing from seam line to seam line and backstitching at each end. Miter corners.

### **Finishing:**

1. Layer the prepared backing, batting and quilt top. Baste and quilt as desired.
2. Trim edges even with quilt top. Sew the prepared Fabric H binding to the edges, turn and stitch in place.

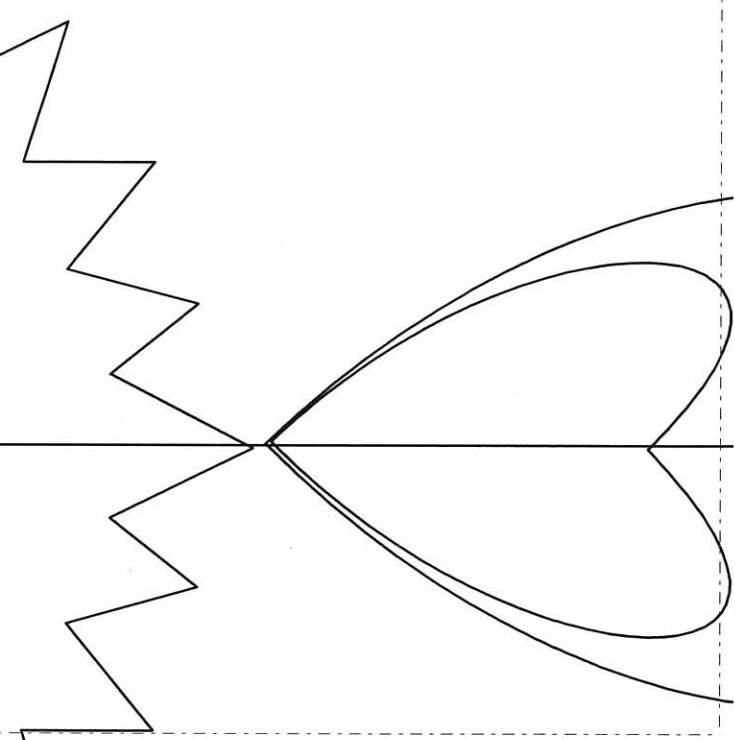
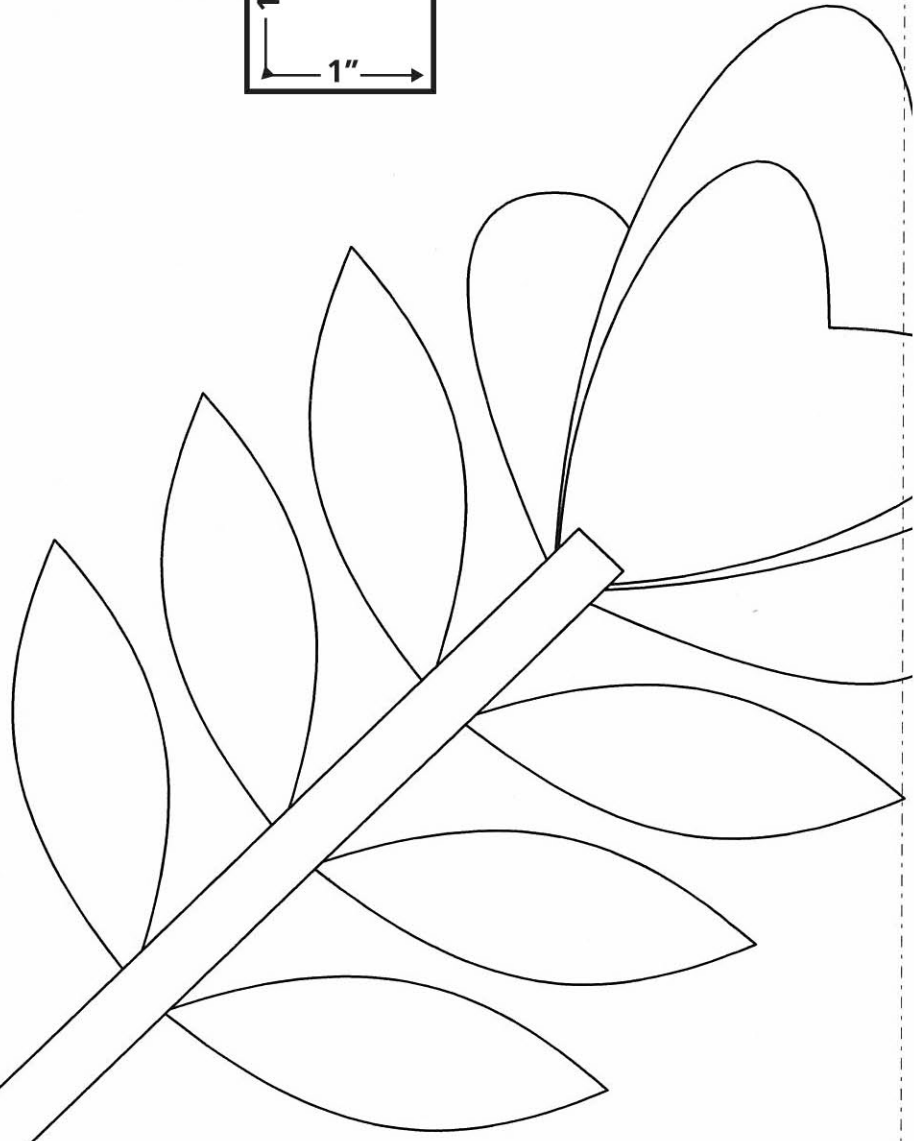
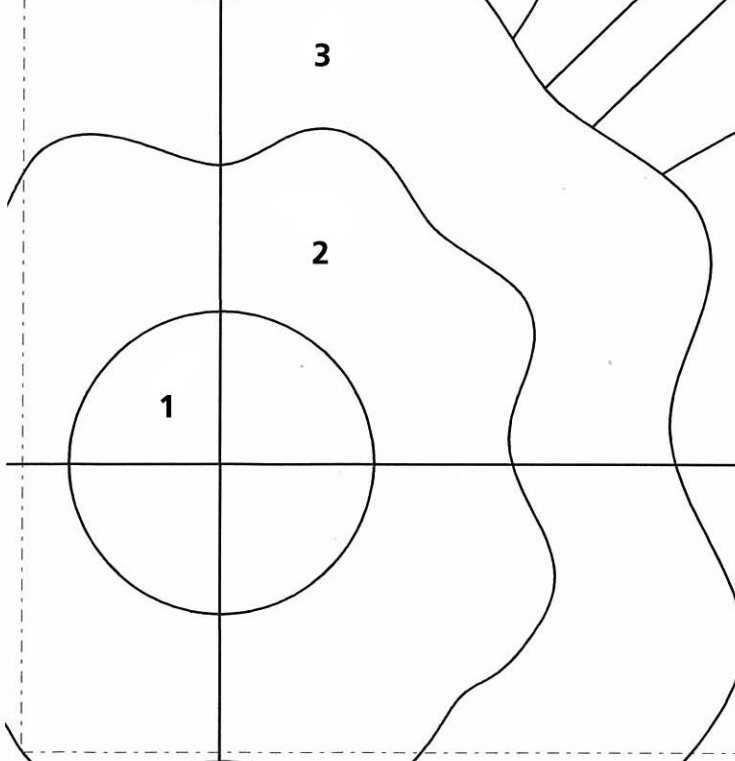
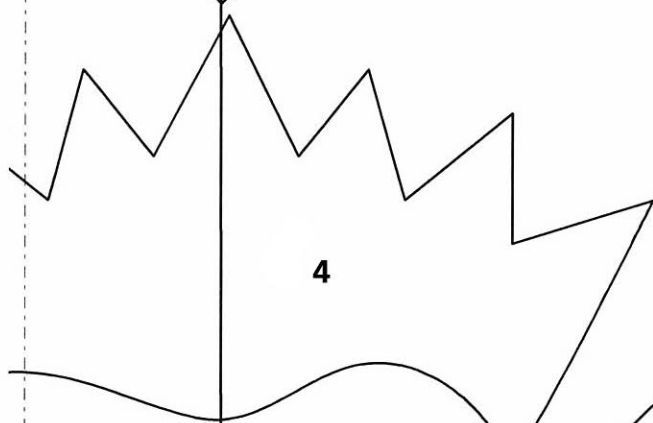
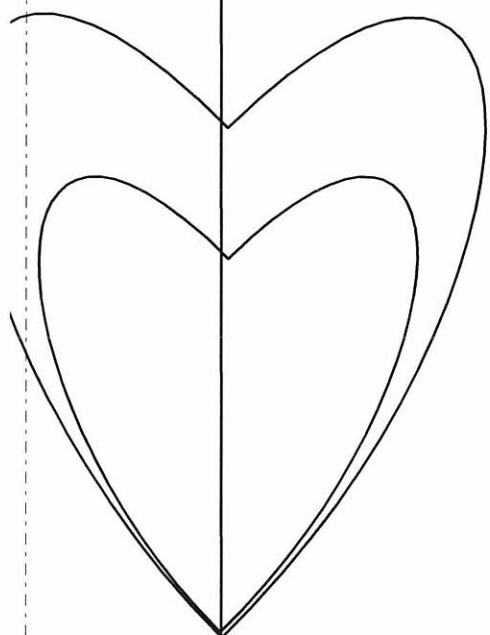
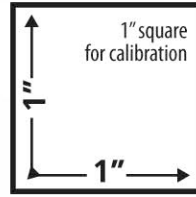

1

2

3

4

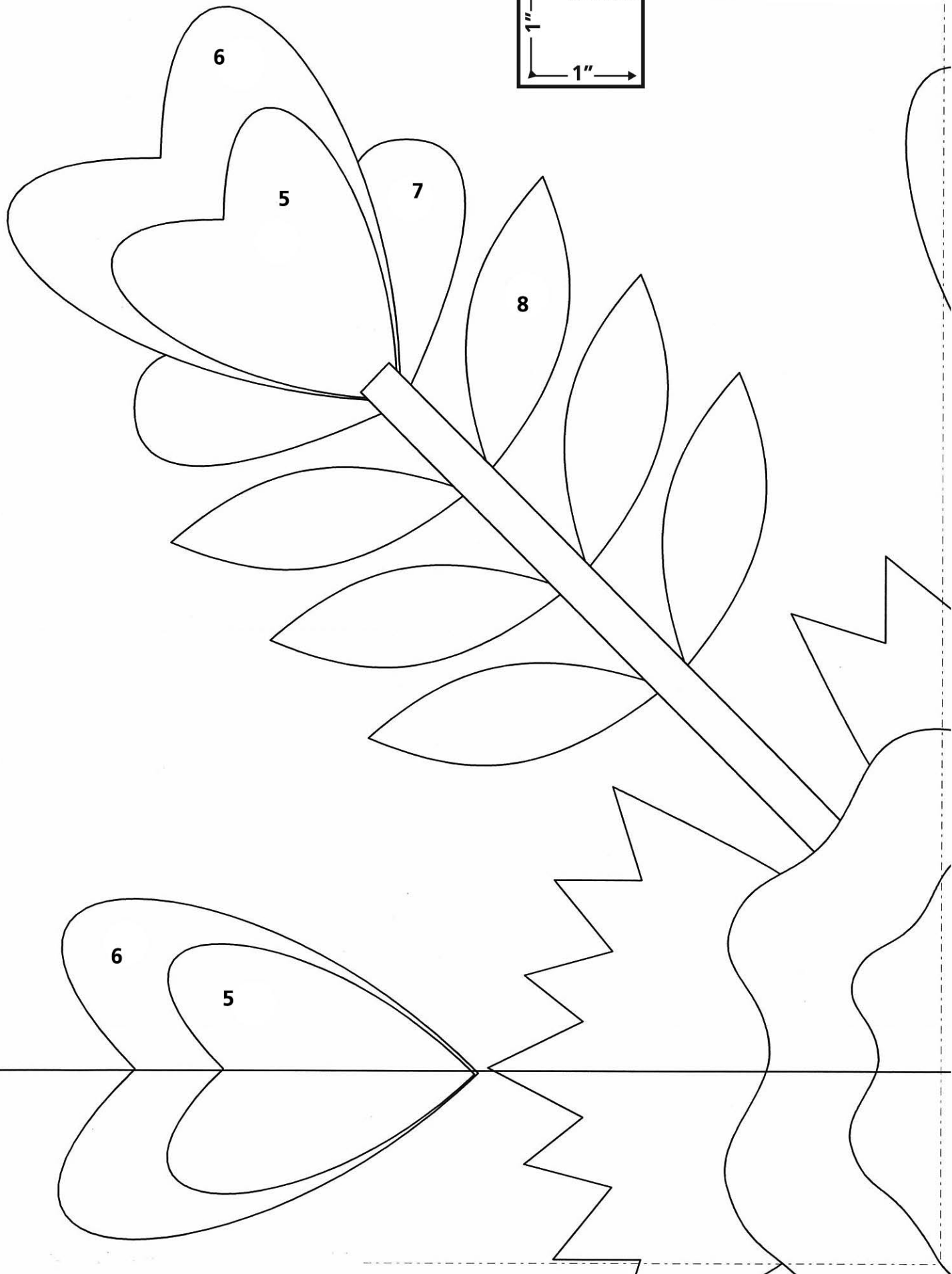
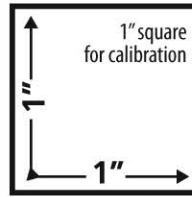

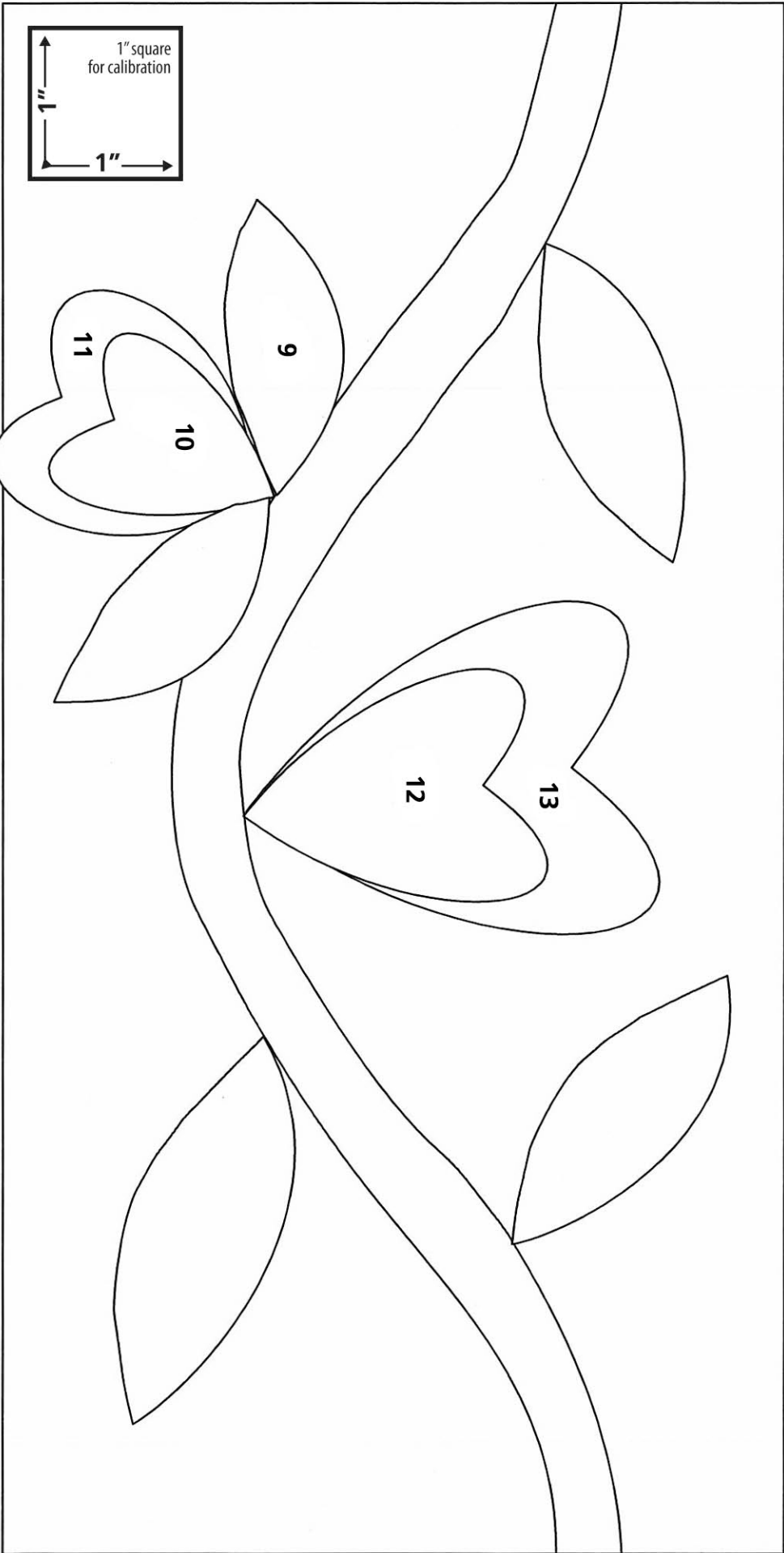

6th border layout

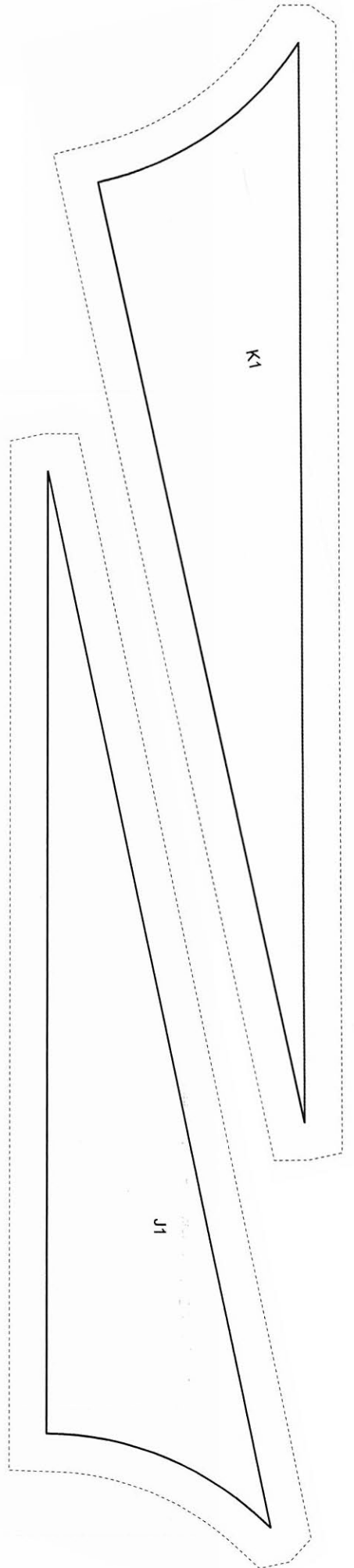

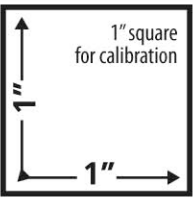

4

11

2

15 / 15 Reverse

14

